

UNIT a (10502)	MAIN	= 877 Sq Ft
	UPPER	= 627 Sq Ft
	TOTAL	= 1504 Sq Ft
	STORAGE/BICYCLE PATIO	= 80 Sq Ft = 86 Sq Ft

UNIT b NEW	MAIN	= 465 Sq Ft
	UPPER	= 442 Sq Ft
	TOTAL	= 907 Sq Ft
STORAGE/BICYCLE	= 68 Sq Ft	

UNIT c NEW	MAIN	= 450 Sq Ft
	UPPER	= 419 Sq Ft
	TOTAL	= 869 Sq Ft
STORAGE/BICYCLE	= 80 Sq Ft	

UNIT d (10504)	MAIN	= 603 Sq Ft
	UPPER	= 535 Sq Ft
	TOTAL	= 1138 Sq Ft
	STORAGE/BICYCLE	= 68 Sq Ft
ACCESSORY CIRCULATION SPACE	= 380 Sq Ft	
	= 4418 Sq Ft	= 762 Sq Ft
GROSS FLOOR AREA = 4418 Sq Ft + 762 Sq Ft = 5180 Sq Ft		

ATTACHED UNITS	MINIMUM	PROVIDED
	3	4

SECOND FLOOR	MINIMUM	PROVIDED
	25 m <sup>2</sup>	58.2 # 41.1 # 38.9 # 49.7 m <sup>2</sup>

ZONING	RM-5 MULTI-FAMILY RESIDENTIAL CONVERT FROM TWO-FAMILY DWELLING TO FOUR TOWNHOUSE DWELLINGS
LOT AREA	MINIMUM 670 m <sup>2</sup> PROVIDED 871 m <sup>2</sup> (9 376 Sq ft)
BASE DENSITY	MAXIMUM 0.75 FAR PROVIDED 0.556 FAR (5 215 / 9 376 = 0.556)
LOT COVERAGE	MAXIMUM 55% PROVIDED $\frac{223 \text{ m}^2(\text{DWELLINGS}) + 71 \text{ m}^2(\text{STORAGE})}{871 \text{ m}^2} = \frac{294.0 \text{ m}^2}{871 \text{ m}^2} = 33.8\%$
AVERAGE GRADE	$\frac{98.7' + 98.9' + 99.7' + 99.1'}{4} = 99.1' (30.20 \text{ m})$ (ASSUMED DATUM, EXISTING MAIN FFL = 100.0' (30.48 m))
BUILDING HEIGHT (+3:12)	MAXIMUM 9 m PROVIDED 7.72 m (25.32 ft)
STOREYS	MAXIMUM 2.5 STOREYS MINIMUM 2 STOREYS PROVIDED 2 STOREYS
SETBACKS	INTERIOR SIDE MINIMUM 1.5 m REAR MINIMUM 3.11 m # 3.61 m FRONT MINIMUM 4.5 m PORCH MINIMUM 4.5 m PROVIDED 14.08 m REAR 4.5 m FRONT 4.5 m PORCH 1.5 m 1.8 m
ADAPTABLE DWELLING	MINIMUM 20% OF NEW = 1 REQUIRED PROVIDED 0 PROVIDED**
ACCESS AISLE	MINIMUM 5.5 m, TWO-WAY PROVIDED 3.45 m, EXISTING**
ACCESSORY BUILDING	% REAR YARD PERMITTED 25% PROVIDED 19.4% WIDTH PERMITTED 50% PROVIDED 35.3% LOCATION REQUIRED REAR/SIDE PROVIDED REAR SETBACK (BUILDING) MINIMUM 1.2 m PROVIDED 1.2 m 1.3 # 2.2 m SETBACK (COLUMN) MINIMUM 1.2 m PROVIDED 0.9 m** HEIGHT MAXIMUM 5.0 m PROVIDED 4.27 m
PARKING	T/HOUSE DWELLINGS MINIMUM 4.0 PROVIDED 4 + 1 SMALL LOCATION REQUIRED REAR/SIDE PROVIDED REAR/SIDE SETBACK MINIMUM 1.0 m PROVIDED 1.0 m AREA MAXIMUM 50% PROVIDED 31.8% BICYCLE REQUIRED 0 PROVIDED 8 CLASS 1

\*\*VARIANCES REQUESTED\*\*

\* NOTE NONCONFORMING PARKING STALL IN FRONT YARD. TO BE MAINTAINED, EXTENDED, AND ALTERED AS PER LOCAL GOVERNMENT ACT S.529.1.b.

LANDSCAPE PLAN	8
STORAGE BUILDING	7
ELEVATIONS	6
ELEVATIONS	5
UPPER FLOOR PLANS	4
MAIN FLOOR PLANS	3
SITE PLAN	2
DATA	1

# units

# zoning

# sheets

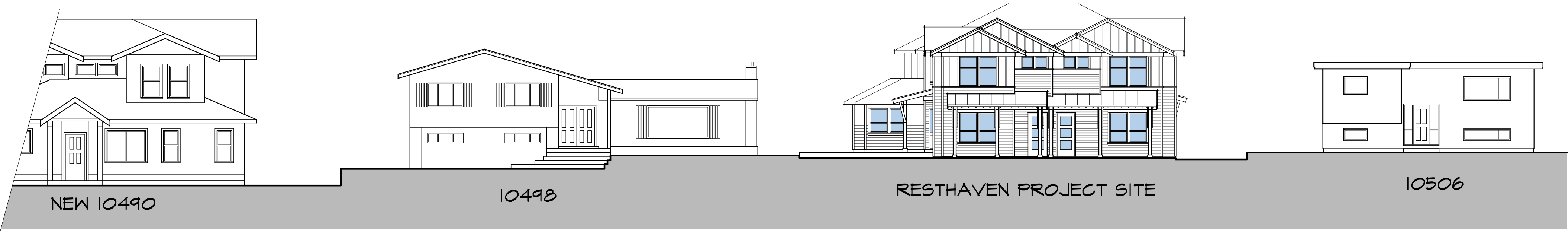

STREETSCAPE  
NOT TO SCALE

AutoCAD SHX Text  
MINIMUM

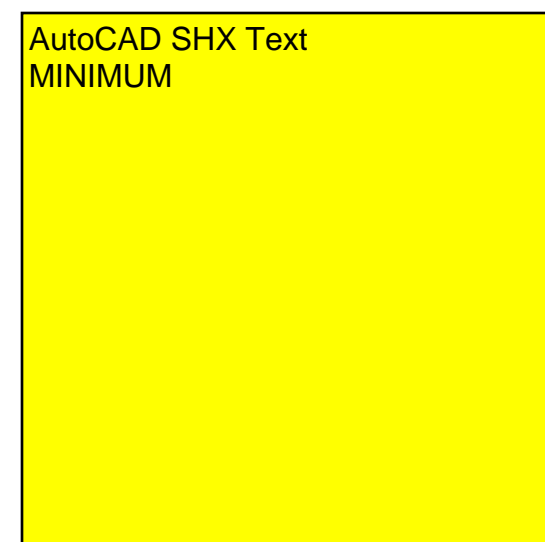
A yellow rectangular box with a black border. The text 'AutoCAD SHX Text' is located at the top left of the box, and 'MINIMUM' is located directly below it.

AutoCAD SHX Text  
TOTAL







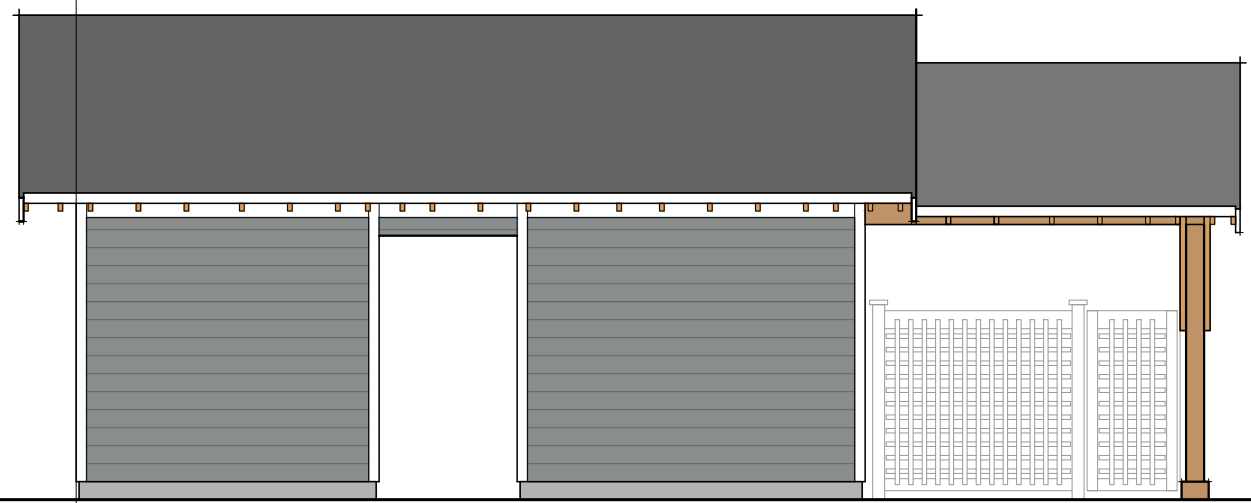

**6 EAST ELEVATION**  
SCALE: 3/16" - 1'-0"

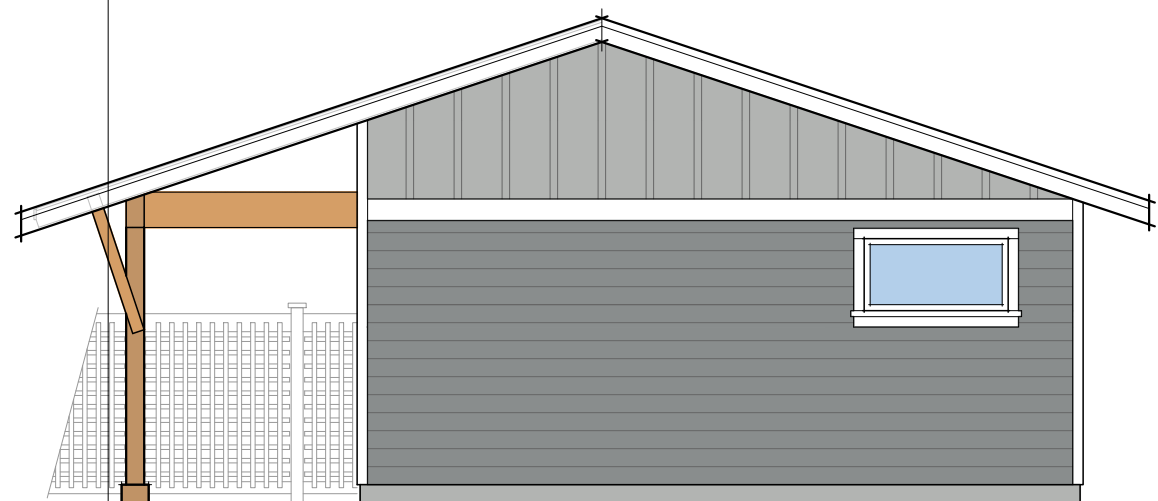

**5 SOUTH ELEVATION**  
SCALE: 3/16" - 1'-0"

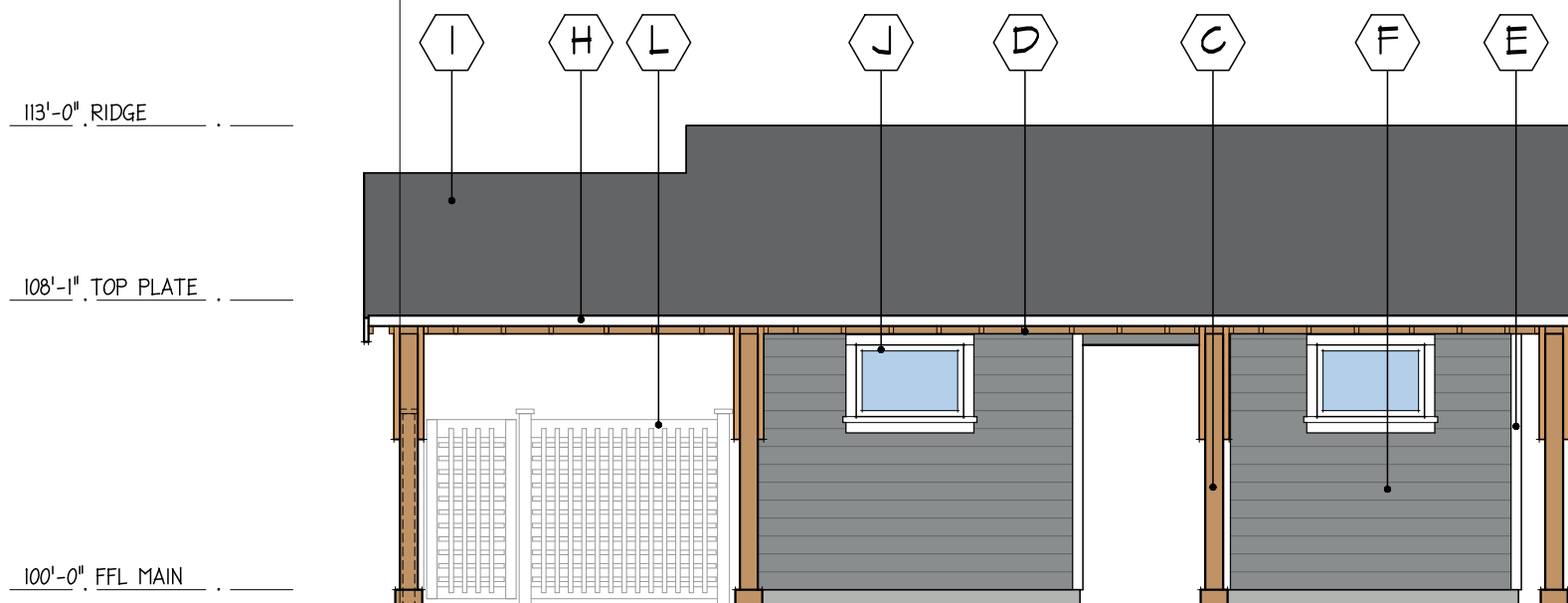

**4 WEST ELEVATION**  
SCALE: 3/16" - 1'-0"

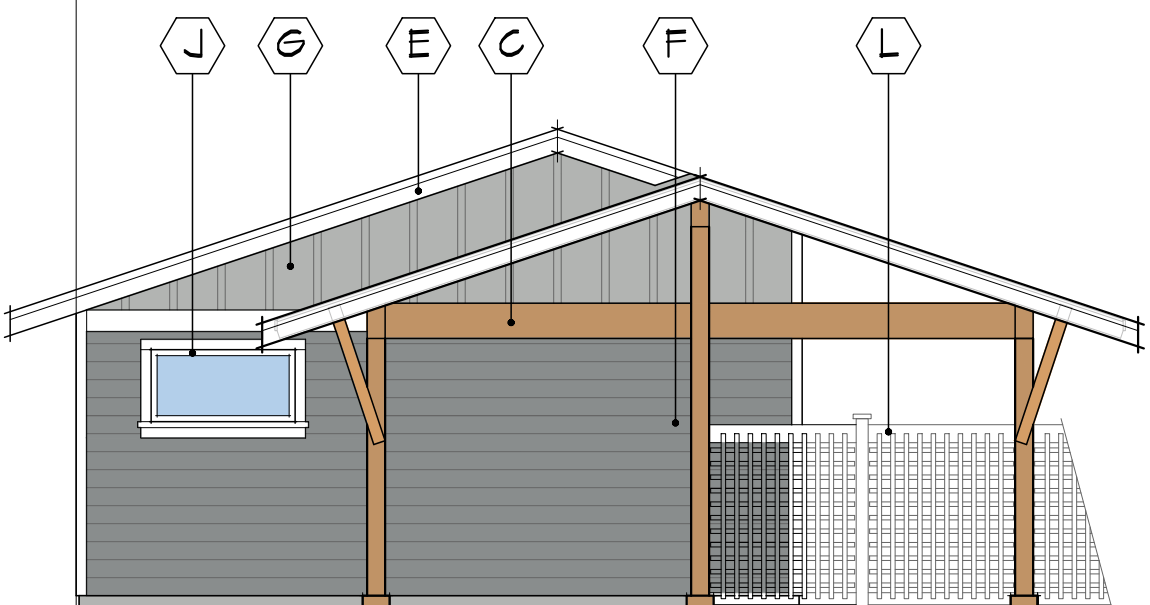

**3 NORTH ELEVATION**  
SCALE: 3/16" - 1'-0"

L	WOOD FENCE STAINED
L	WINDOWS - VINYL WHITE
I	FIBREGLASS LAMINATED SHINGLES MALARKEY HIGHLANDER - MIDNIGHT BLACK
H	ALUMINUM GUTTER + DOWNSPOUTS WHITE
G	FIBRE-CEMENT PANELS, WOOD BATTENS CLOVERDALE "FROST" - EX03T
F	FIBRE-CEMENT, SMOOTH PLANKS, 6" EXPOSURE CLOVERDALE "CHARRED COAL" - EX025
E	WOOD TRIMS - PAINT CLOVERDALE STANDARD WHITE - EX023
D	WOOD RAFTERS - STAIN SANGIN NATURAL CEDAR - 1101
C	WOOD BEAMS + COLUMNS - STAIN SANGIN NATURAL CEDAR - 1101

**materials**

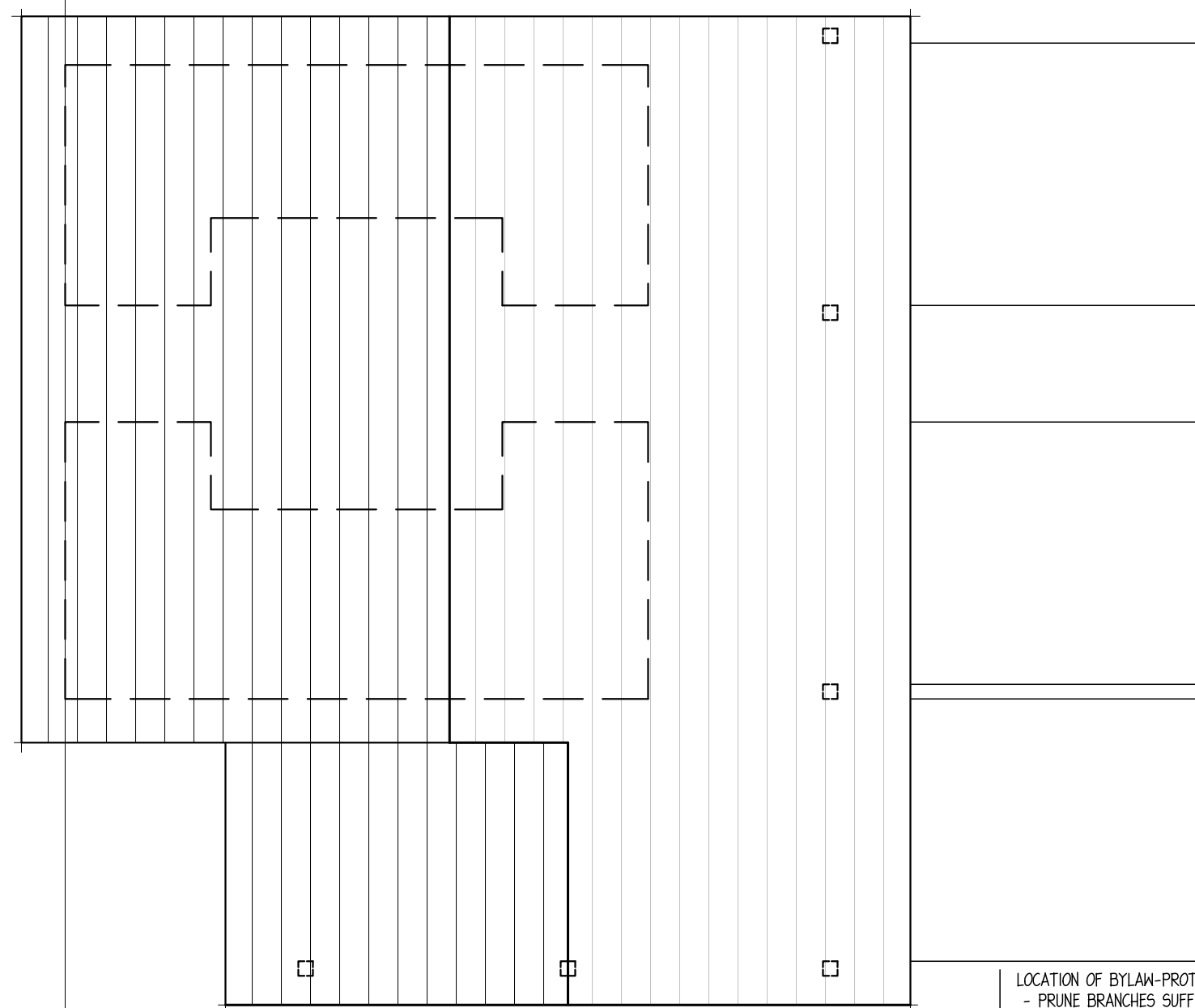

**2 ROOF PLAN**  
SCALE: 3/16" - 1'-0"

LOCATION OF BYLAW-PROTECTED FIR TREE:  
- PRUNE BRANCHES SUFFICIENT TO ACCOMMODATE NEW ACCESSORY BUILDING  
- PROTECT ROOT ZONE DURING CONSTRUCTION  
- EXCAVATE BY HAND TO MINIMIZE ROOT DISRUPTION  
- DESIGN AND CONSTRUCT FOUNDATION TO MINIMIZE IMPACTS TO THE TREE  
- ALL SUBJECT TO APPROVAL OF THE TOWN OF SIDNEY ARBORIST

SETBACK TO COLUMN  
\*\* VARIANCE REQUESTED \*\*

REQUIRED SETBACK (0.6m) FOR ROOF OVERHANG, TYPICAL

REQUIRED SETBACK (1.2 m) FOR ACCESSORY BUILDING, TYPICAL

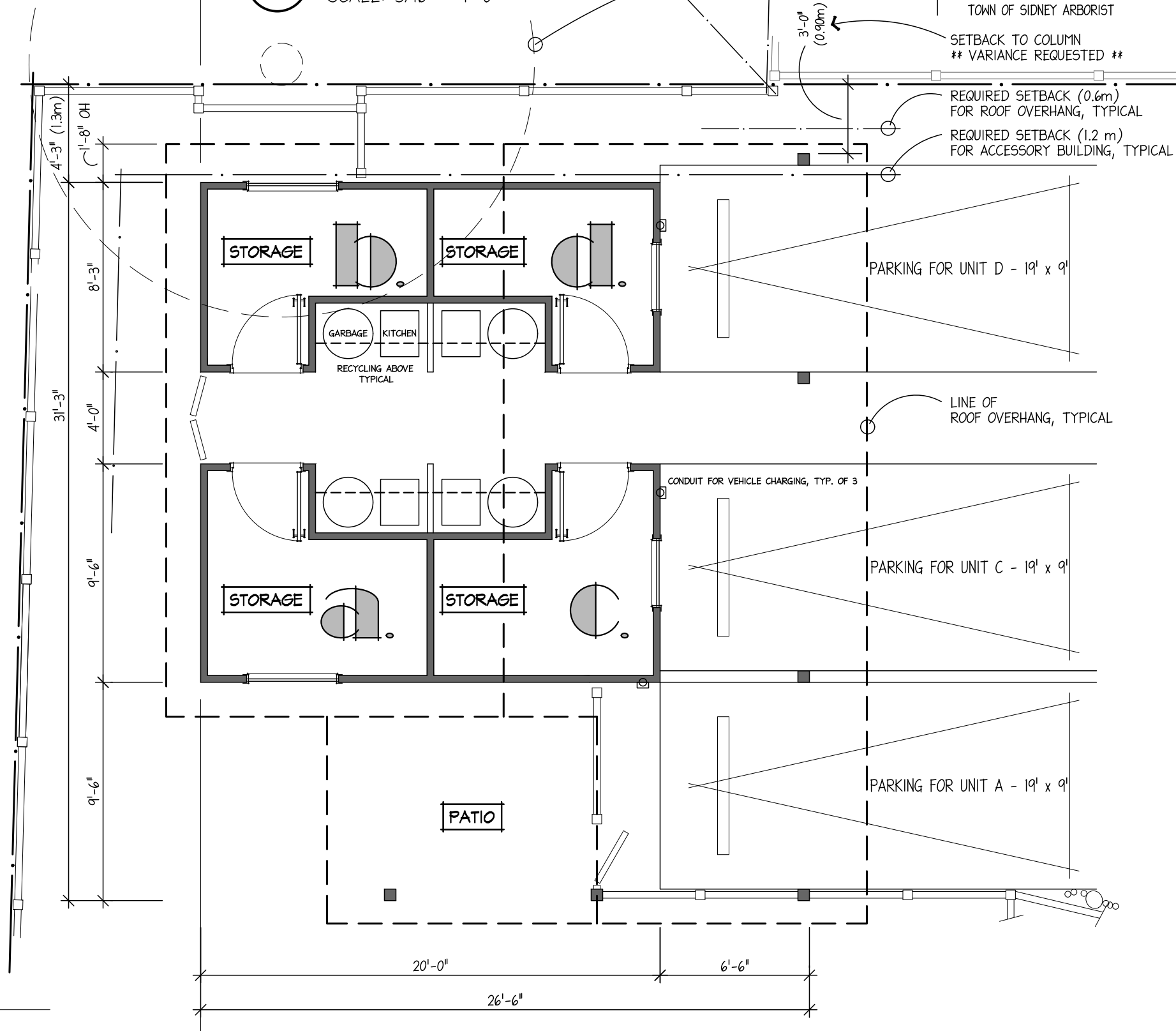

**1 FLOOR PLAN**  
SCALE: 3/16" - 1'-0"

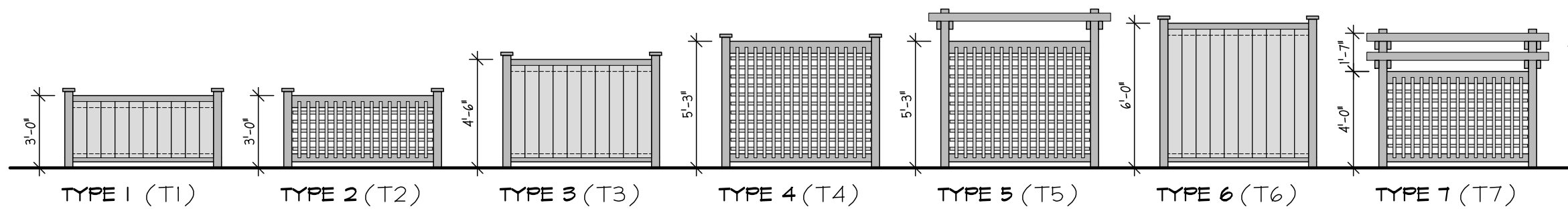

### 3 FENCE TYPES

SCALE: 3/16" = 1'-0"

KEY	BOTANICAL NAME	COMMON NAME	SIZE
Az	AZALEA JAPONICA	EVERGREEN AZALEA	#2 pot
B	BRUNNERA MACROPHYLLIA	SIBERIAN BUGLOSS	#1 pot
Bs	BLECHNUM SPICANT	DEER FERN	#1 pot
Bx	BUXUS SEMPERVIRENS	COMMON BOXWOOD	#2 pot
Ca	CLEMATIS ARMANDII	EVERGREEN CLEMATIS	#2 pot
Cn	CLEMATIS 'NELLY MOSER'	CLEMATIS	#2 pot
E	ESCALLONIA FRASERII	ESCALLONIA	#5 pot
F	FATSIA JAPONICA	FATSIA	#5 pot
H	HEUCHERA AMERICANA	CORAL BELLS	#2 pot
Hm	HAKONECHLOA MACRA	JAPANESE FOREST GRASS	#2 pot
Ho	HOSTA SIEBOLDI	PLANTAIN LILY	#2 pot
Hp	HEBE 'PATTY'S PURPLE'	HEBE	#5 pot
Hs	HEMEROCALLIS 'STELLA D'ORO'	DAY LILY	#2 pot
Hy	HYDRANGEA PANICULATA	HYDRANGEA	#5 pot
Kf	CALAMAGROSTIS 'KARL FOERSTER'	FEATHER REED GRASS	#1 pot
La	LAVANDULA ANGUSTIFOLIA	ENGLISH LAVENDER	#2 pot
Lh	LONICERA JAPONICA 'HALLIANA'	HONEYSUCKLE VINE	#2 pot
Ms	MISCANTHUS SINENSIS	MAIDENHAIR GRASS	#5 pot
Rb	RHODODENDRON 'BOW BELLS'	RHODODENDRON	#2 pot
Ru	RHODODENDRON 'UNIQUE'	RHODODENDRON	#5 pot
Rs	RIBES SANGUINEUM	RED FLOWERING CURRANT	#5 pot
Rw	RIBES SANGUINEUM	WHITE FLOWERING CURRANT	#5 pot
Sh	SARCACocca HUMULIS	HIMALAYAN SWEET BOX	#2 pot
St	STIPA TENUISSIMA	MEXICAN FEATHER GRASS	#1 pot
Tb	TAXUS BACCATA 'FASTIGIATA'	IRISH YEW	#2 pot
V	VINCA MINOR	EVERGREEN PERIWINKLE	Sp3
Lawn	GRASS	LAWN	
Tree	MAGNOLIA STELLATA	STAR MAGNOLIA	6 cm cal.

NOTES:

- ALL PLANTING BEDS AND LAWN AREAS TO HAVE AN AUTOMATIC IRRIGATION SYSTEM THAT CONFORMS TO IABC STANDARDS.
- ALL PLANTING TO CONFORM TO BCNLA/BCSLA STANDARDS.
- ALL PLANTING BEDS TO BE TOPDRESSED WITH 50 cm BARK MULCH.

### 2 PLANT LIST



### 1 LANDSCAPE PLAN

SCALE: 3/32" = 1'-0"